

### Incident description: gas leak 2015

When switching from main generator B to main generator A, the turbine stopped and a single gas detection was received from the turbine hood. The latter was checked for gas, but not the gas well. A new start attempt resulted in a further turbine stop. Gas was detected by two detectors in the turbine hood as well as in the air intake for the ballast- and fire-pump rooms. ESD 1 was initiated, main power was lost, and a general alarm was activated. The emergency generator started as normal.

The fuel gas system supplies the turbine with hot gas. The supply line in the fuel gas system is heated to 15°C above the dew point by opening valve 1 to the low-pressure flare. This is done to avoid droplets in the gas. Valve 2 is open to the local vent. Valves 1 and 2 are then opened to the turbine and lead the gas there. In the event of a stop, the fuel gas supply line must be blown down. An ESD valve shuts off the supply from the fuel gas system. Valves 1 and 2 open simultaneously to the low-pressure flare and the local vent (safe location). This establishes a depressurised safe condition with double block and bleed against the turbine.

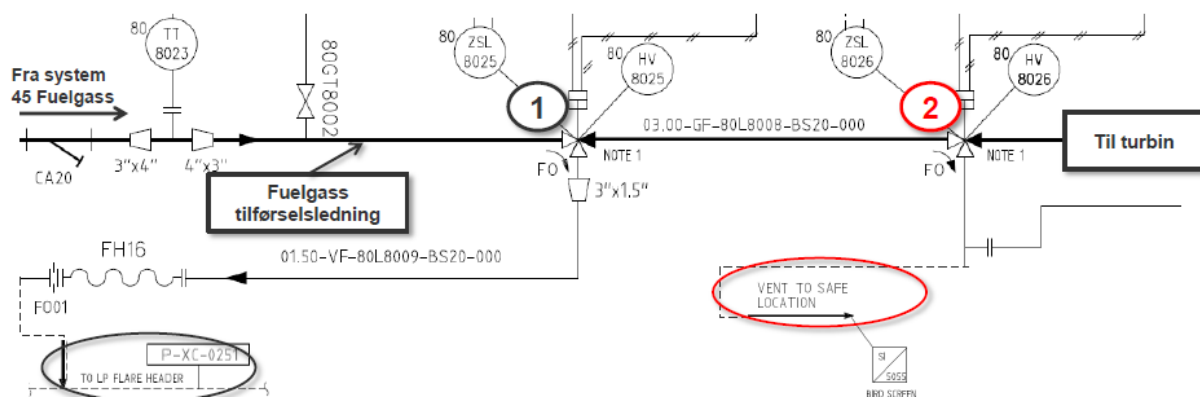

Figure 1: Fuel gas system supplying/heating up the turbine.

Valve 2 is a three-way valve with three functions:

- AB fuel gas in
- A fuel gas to main generator A
- B fuel gas to vent/safe location.

In the actuator, compressed air is led over an air bellows and depresses the spring. The stem will then push the valve plug down and close against vent (B). The valve is spring-based to fail open to vent (B). The air bellows in the actuator sprang a leak because it had perished. This leak meant that the bellows function was lost and the springs overrode the counterpressure. The valve was therefore put in an intermediate position, which allowed fuel gas to flow to both valve (B) and turbine (A). That resulted in a hydrocarbon gas leak through an inadequately plugged vent. The leak rate is estimated at 2.3kg/s, with a total discharge of 6.9kg.

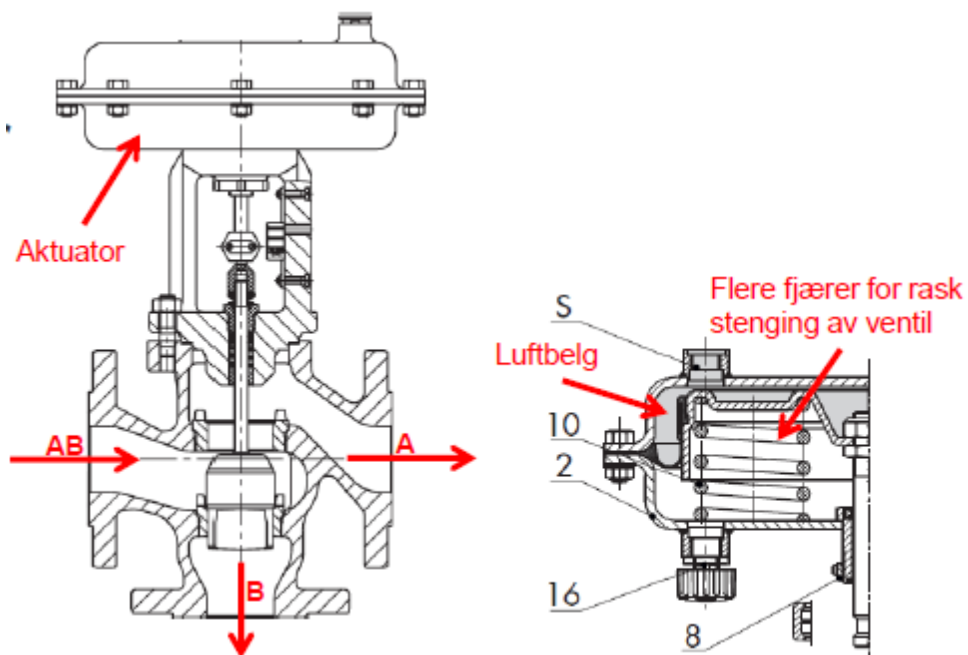

Figure 2: Three-way valve similar to valve 2 in figure 1, as well as a cross-section of the actuator.



Figure 3: Perished and cracked air bellows.

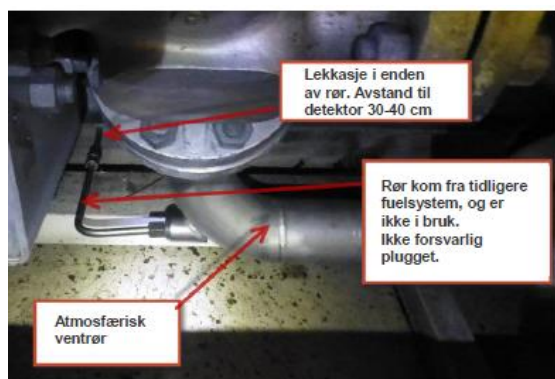

Figure 4: Gas leak turbine hood (skirt).

## Causes

### Direct cause

- Hydrocarbon leak as the result of leaking air bellows in the actuator.

### Underlying causes

- The reason for the trip was an LL signal for fuel gas pressure in the supply line.
- Air leakage from the actuator meant that the three-way valve (set at open to the safe location) in the fuel gas supply line failed and did not close completely against the vent. This then caused the LL signal for fuel gas pressure.
- A new start attempt again produced an LL signal for fuel gas pressure.
- The three-way valve remained almost fully open against the vent to the safe location, and caused a gas leak in an unclassified area.
- The air bellows was perished with clearly visible cracks. This meant the actuator lacked the power to open the three-way valve, which remained in an intermediate position and released gas to both turbine and vent.
- The three-way valve was assessed to be of low criticality and was therefore not maintained.
- The vent to the safe location is not designed to handle such volumes of gas.
- The tubing for air supply to the actuator is incorrectly dimensioned. It was too small, so that higher pressure was needed to open the three-way valve quickly enough.
- Inadequate plugging of tubing from packing boxes to vents (which were no longer in use).

## Lessons and recommendations

- Assess the point for releasing gas to the safe location in relation to the gas quantity in the event of valve failure, and where the gas is vented to.
- The criticality of three-way valves should be assessed and a preventive maintenance programme introduced. Should criticality be changed, a spare part assessment ought to be made.
- Three-way valves should be replaced at the same time as valve replacement.
- When communicating about gas detection by walkie-talkie, the tag number, alarm text, alarm description and detector location should be specified.
- The following routines should be reported/considered at turbine start-up:
  - person in charge of the area must be notified of the planned start-up
  - personnel present in the area concerned
  - use of gas meters/sniffers when starting up for a second time in an area with detection.
- Greater attention to punching and quality variations from the supplier at handover of operational projects/modifications.
- Establish an HSE report which must be viewed in relation to similar events on other installations.